

OWNER'S MANUAL
Model No. GRP6PBWTT

GEORGE FOREMAN®

**LEAN
MEAN
FAT REDUCING
GRILLING
MACHINE!**

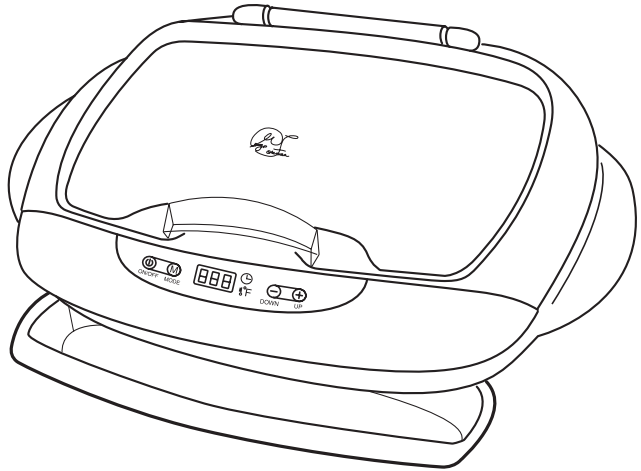
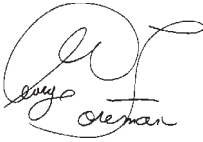

THE NEXT GRILLERATION

The Salton logo features a stylized globe with latitude and longitude lines above the word "salton" in a bold, lowercase, sans-serif font. A registered trademark symbol (®) is located to the right of the word.

IMPORTANT SAFEGUARDS

When using electrical appliances, basic safety precautions should always be followed, including the following:

1. Read all instructions.
2. Do not touch hot surfaces. Use handles or knobs. Use oven mitts or pot holders.
3. To protect against electric shock, do not immerse cord, plug, or appliance in water or other liquid.
4. Close supervision is necessary when any appliance is used by or near children.
5. Unplug from outlet when not in use and before cleaning. Allow to cool before putting on or taking off parts, and before cleaning the appliance.
6. Do not operate any appliance with a damaged cord or plug or after the appliance malfunctions, or has been damaged in any manner. Contact Consumer Service for examination, repair or adjustment.
7. The use of accessory attachments not recommended by the appliance manufacturer may cause injuries.
8. Do not use outdoors.
9. Do not let cord hang over edge of table or counter, or touch hot surfaces.
10. Do not place on or near a hot gas or electric burner, or in a heated oven.
11. Extreme caution must be used when moving an appliance containing hot oil or other hot liquids. Allow liquid to cool before removing and emptying drip tray.
12. To disconnect, press Power On/Off Button to OFF, (Display shows - - -) grasp plug and remove from outlet.
13. Do not use appliance for other than intended use.

SAVE THESE INSTRUCTIONS

FOR HOUSEHOLD USE ONLY

ADDITIONAL IMPORTANT SAFEGUARDS

CAUTION HOT SURFACES: *This appliance generates heat and escaping steam during use. Proper precautions must be taken to prevent the risk of burns, fires or other injury to persons or damage to property.*

CAUTION: *This appliance is hot during operation and retains heat for some time after turning off. Always use oven mitts when handling hot materials and allow metal parts to cool before cleaning. Do not place anything on top of the appliance while it is operating or while it is hot.*

1. All users of this appliance must read and understand this Owner's Manual before operating or cleaning this appliance.
2. The cord to this appliance should be plugged into a 120V AC electrical outlet only.
3. If this appliance begins to malfunction during use, immediately unplug cord from outlet. Do not use or attempt to repair the malfunctioning appliance.
4. Do not leave this appliance unattended during use.
5. When using this appliance, provide adequate air space above and on all sides for air circulation. Do not allow this appliance to touch curtains, wall coverings, clothing, dish towels or other flammable materials during use.
6. This appliance generates steam — do not operate in open position.
7. **Using pot holder, hold the top cover (Lid) open while placing or removing food on the cooking surface to prevent accidental closing and injury.**

Polarized Plug

This appliance has a **polarized plug** (one blade is wider than the other). To reduce the risk of electric shock, this plug is intended to fit into a polarized outlet only one way. If the plug does not fit fully in the outlet, reverse the plug. If it still does not fit, contact a qualified electrician. Do not attempt to modify the plug in any way.

Short Cord Instructions

A short power-supply cord is provided to reduce the risk resulting from becoming entangled in or tripping over a longer cord.

Do not use an extension cord with this product.

Electric Power

If the electrical circuit is overloaded with other appliances, your appliance may not operate properly. It should be operated on a separate electrical circuit from other appliances.

Plasticizer Warning

CAUTION: To prevent Plasticizers from migrating from the finish of the countertop or tabletop or other furniture, place **NON-PLASTIC** coasters or placemats between the appliance and the finish of the countertop or tabletop.

Failure to do so may cause the finish to darken, permanent blemishes may occur or stains can appear.

Getting To Know Your GRP6PBWTT Grilling Machine

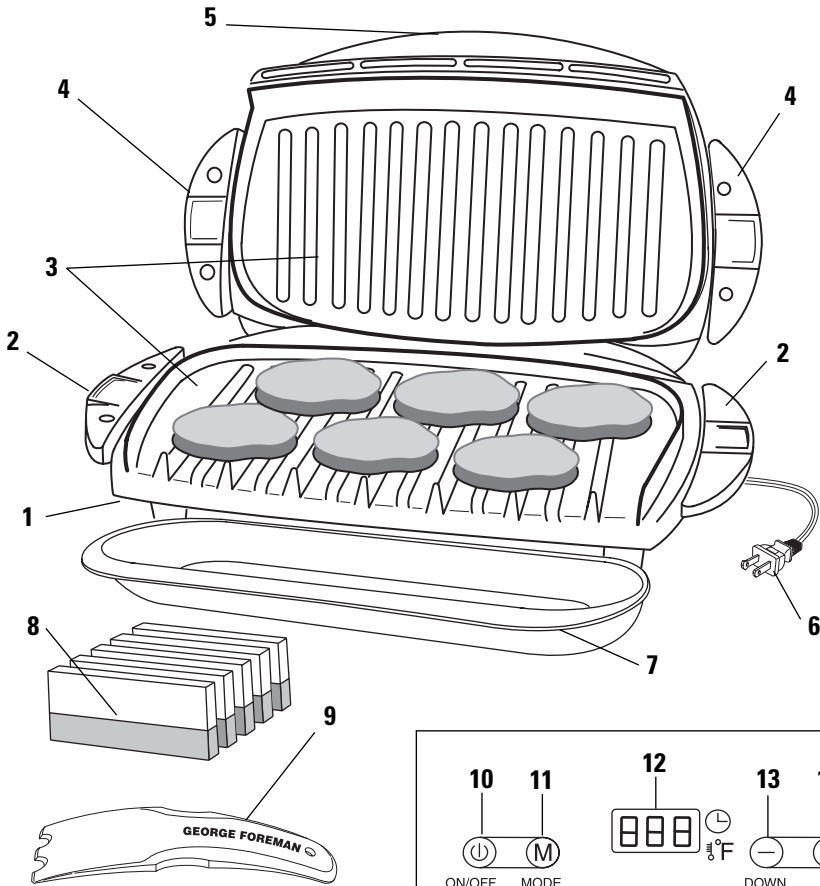

1. Grilling Machine Body
2. Grilling Plate Release Handles, Lower
3. Grilling Plates
Upper Grilling Plate (P/N 22673U)
Lower Grilling Plate (P/N 22673L)
4. Grilling Plate Release Handles, Upper
5. Bun Warmer Cover Location

6. Cord
7. Drip Tray (P/N 22674)
8. Grill Sponge (GFSP1)
9. Plastic Spatula (P/N 22545)
10. Power On/Off Button
11. MODE Button
12. Display Window (LED)
13. DOWN Button
14. UP Button

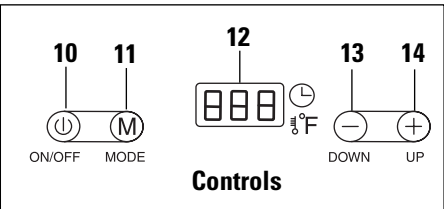

How To Use George Foreman's Lean Mean Fat Reducing Grilling Machine

1. Before using the Grilling Machine for the first time, wipe the Grilling Plates with a damp cloth to remove any dust and make sure both Grilling Plates are firmly attached to the appliance.
2. **To preheat:** Close the Lid and plug the cord into a 120V AC outlet. The Display will show " - - ", indicating that the appliance is off. Turn the appliance on by pressing the **ON/OFF** Button. The Display will show "5", indicating the start of the 5 minute preheat countdown. The **MODE** Button allows you to toggle between Time and Temperature modes. Press the **MODE** Button to enter the Temperature mode. The Display will show a flashing "300". This is the default temperature level. Adjusting the temperature allows you to cook your food at a specific heat setting, within a range of 300°F to 425°F, in 25° increments. If a higher temperature is preferred, press the **UP** Button until that temperature is displayed. Press the **DOWN** Button to decrease the temperature setting. See **Suggested Cooking Chart** for specific details. Allow the Grilling Machine to preheat. When the 5 minute countdown is complete the unit will beep 4 times. **Note:** If temperature reaches displayed temperature before 5 minutes the temperature display will stop flashing and the unit will beep 4 times. The Temperature Display will stay illuminated as a reminder that the power is still on. If the Temperature Display is still flashing, the set temperature has not yet been reached. When the set temperature is reached the unit will again beep 4 times and the temperature display will remain on.
3. Use a pot holder to carefully open the Lid.
4. Slide the grease catching Drip Tray under the front of the unit.
5. Carefully place the items to be cooked on the bottom grilling plate.
6. Close the Lid and press the **MODE** Button to return to the Time mode. Adjusting the time allows you to cook your food for a specific duration, up to 20 minutes, in 1 minute increments. Press the **UP** Button to increase grilling time. Press the **DOWN** Button to decrease grilling time.
7. Allow the food to cook for the desired time. **Do not leave appliance unattended during use!** When the set time has elapsed, the unit will beep 4 times. **Reminder: The heat continues to be "on" until the appliance is turned OFF.** **Note:** The Grilling Machine will automatically shut-off one hour after you have turned it on. To continue cooking, press the **ON/OFF** Button and reset temperature and time as needed.
8. When grilling is complete, press the **ON/OFF** Button to turn the appliance off. The Display will show " - - - ". Disconnect the plug from the wall outlet. **CAUTION: To avoid any sparks at the outlet while disconnecting plug, make sure the power is off (Display shows - - -) before disconnecting the plug from the outlet.**
9. Use a pot holder to carefully open the Lid.
10. Remove the food using the Plastic Spatula provided. Be sure to always use either plastic or wooden utensils so as not to scratch the non-stick surface. Never use metal tongs, forks or knives as these can damage the coating on the grilling plates.
11. When cool, the Drip Tray may be removed and emptied. **Be sure the liquid has cooled before removing Drip Tray.**

Using the Bun Warmer

This model comes equipped with a Bun Warmer. You can use this feature to warm various kinds of bread products (hamburger buns, breakfast biscuits, English muffins, tortillas, pita bread, sliced bagels, and mini croissants). For example, if you are cooking hamburgers, you can place your hamburger buns inside the Bun Warmer to warm them while you cook the hamburgers! **REMEMBER: The Bun Warmer should be used to warm bread products only. It will not cook or grill any item. It is not intended for defrosting.** The Bun Warmer cannot hold very thick bread products. If a bread product is too thick, you may have to cut it (butterfly) to fit.

1. Bun Warmer Cover (P/N 22675C)
2. Lid Latch (P/N 22676C)

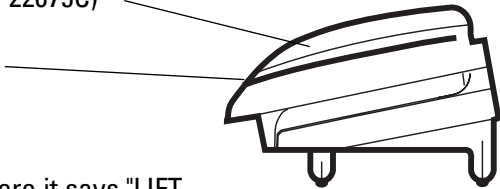

To use the Bun Warmer:

1. Lift up the Lid Latch (where it says "LIFT TO OPEN").
2. Place the bread product inside the Bun Warmer.
3. When bread is in place, close the Lid by lifting up on the Latch, lowering the Lid, and latching it into place. **NEVER FORCE THE LID CLOSED. Press gently to close Lid.**
4. Allow 2-3 minutes after the machine has warmed up to complete heating. If you are placing bread products in the Bun Warmer that have been refrigerated, they will take longer to warm up.

CAUTION: The Bun Warmer does not have a separate operation switch. If you want to warm some bread, but do not want to cook anything on the grill, please be aware that the grill will be on and will become very hot.

WARNING: Do not keep cooked food (such as meat, vegetables, potatoes, etc.) warm in the Bun Warmer! THE BUN WARMER IS FOR BREAD PRODUCTS ONLY!

NOTE: The Bun Warmer cover is specially designed for easy use. The lid is removeable, you can take it off for cleaning. To remove the cover, raise it to an angle of 50 degrees and lift the cover at the two hinge connections. Reverse this procedure to reassemble.

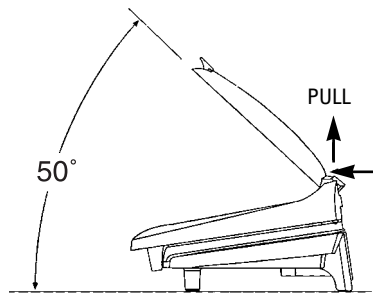

Suggested Cooking Chart

The following times are meant to be used as guidelines only. Times will vary due to the cut or thickness of the meat being cooked. To be sure that the food is truly done, use a cooking thermometer. If the food does need more time to cook, reset the timer and check periodically so you do not overcook.

When cooking the following items, we recommend setting your Grilling Machine to 300°F:

	Medium Rare 145°F*	Medium 160°F*	Well 170°F*
Salmon Filet, 1" thick, 4 oz each	7-8 min.	9-10 min.	
Salmon Steak, 1" thick, 10 oz each	8-9 min.	11-12 min.	
Sword Fish, 1" thick, 6 oz each	8-9 min.	10-11 min.	
Tuna Steak, 1" thick, 6 oz each	6-7 min.	8-9 min.	
White Fish, 1/2" thick, 6 oz each	2-3 min.	4-5 min.	
Turkey Burger, 3/4" thick, 4 oz each			8-10 min.
Turkey Burger, 1" thick, 8 oz each			11-13 min.
Frozen Turkey Burgers, 3/4" thick, 4 oz each			11-13 min.
Frozen Turkey Burgers, 1" thick, 8 oz each			14-16 min.
Sea Scallops, 1" thick, 1 oz each	3-4 min.	4-5 min.	
Shrimp, Split Shell, med. size, 1/2 lb.		2-3 min.	

When cooking the following items, we recommend setting your Grilling Machine to 350°F:

Center Cut Pork Chops, 1/2" thick, 6 oz each		8-9 min.	10-11 min.
Pork Tenderloin, 1/2" thick, 2 oz each		3 min.	5-6 min.
Hamburger, 3/4" thick, 4 oz each		7-8 min.	9-10 min.
Hamburger, 1" thick, 8 oz each		9-10 min.	11-12 min.
Frozen Hamburger, 3/4" thick, 4 oz each		9-10 min.	11-12 min.
Frozen Hamburger, 1" thick, 8 oz each		15-16 min.	17-18 min.
Chicken Breast (boneless/skinless) 1 1/2" thick, 6-8 oz each			9-10 min.
Frozen Chicken Breast (boneless/skinless) 1 1/2" thick, 6-8 oz each			12-13 min.
Link Sausage		4-5 min.	5-6 min.
Sliced Sausage (1/2" thick)		4-5 min.	5-6 min.
Brats		5-6 min.	6-7 min.
Hot Dogs			5-6 min.
Ham Steak, 3/4" thick, 4 oz each		4-5 min.	5-6 min.

When cooking the following items, we recommend setting your Grilling Machine to 400°F:

Fajita Beef (1/2" thick slices)	1-2 min.	2-2 1/2 min.	2 1/2-3 min.
T-Bone Steak, 3/4" thick, 12 oz each	3-4 min.	4-5 min.	5-6 min.
Frozen T-Bone, 3/4" thick, 16 oz each	8-9 min.	11-12 min.	13-14 min.
NY/KC Strip Steak, 3/4" thick, 8 oz each	7-8 min.	8-9 min.	9-10 min.
Frozen NY/KC Strip Steak, 3/4" thick, 8 oz each	7-8 min.	8-9 min.	9-10 min.
Ribeye Steak, 3/4" thick, 12 oz each	5-6 min.	6 1/2-7 1/2 min.	8-9 min.
Frozen Ribeye Steak, 3/4" thick, 10 oz each	9-10 1/2 min.	10-11 1/2 min.	11-12 1/2 min.
Onions and Peppers (brush with olive oil)		7-8 min.	9-10 min.

PLEASE NOTE: The USDA recommends that meats such as beef and lamb, etc. should be cooked to an internal temperature of 145°F. Pork should be cooked to an internal temperature of 160°F and poultry products should be cooked to an internal temperature of 170°F - 180°F to be sure any harmful bacteria has been killed. When reheating meat/poultry products, they should also be cooked to an internal temperature of 165°F.

* Internal Food Temperatures

User Maintenance Instructions

CAUTION: To avoid accidental burns, allow your Grilling Machine to cool thoroughly before cleaning.

1. Before cleaning, unplug the appliance from the wall outlet and allow to cool.

CAUTION: To avoid any sparks at the outlet while disconnecting plug, make sure the power is off (Display shows - - -) before disconnecting the plug from the outlet.

2. **Inside cleaning:** Place the Drip Tray under the front of the Grilling Machine. Using the specially designed Spatula, scrape off any excess fat and food particles. Run off will drip into the Drip Tray. Wipe the plates with the George Foreman specially designed Grill Sponge.
3. Empty the Drip Tray and wash with warm soapy water. The Grilling Plates may be removed from the appliance by pulling out on the Grilling Plate Release Handles. Wash in warm, soapy water, rinse and dry thoroughly. Reinstall the Grilling Plates, making sure they are securely attached to the appliance. The removable Grilling Plates are also dishwasher safe. After washing the Plates in the dishwasher, wipe the uncoated side with a dry towel to prevent discoloration. Dishwasher detergent may cause oxidation on the uncoated side of the cooking plate. This is not harmful and can be wiped off with a damp towel.
4. **Stubborn build-up:** Use the scouring side of the Grill Sponge to clean the plates.
5. **Outside cleaning:** Wipe with a warm, wet sponge and dry with a soft, dry cloth.

To clean the Bun Warmer surface, simply wipe with a clean, damp cloth or sponge. Do not use harsh or abrasive cleaners.

6. Do not use steel wool, scouring pads, or abrasive cleaners on any part of the appliance.
7. **DO NOT IMMERSE THE BODY OF THE APPLIANCE IN WATER OR OTHER LIQUID.**
8. Any servicing requiring disassembly other than the above cleaning must be performed by a qualified electrician.
9. Make sure to hold the top cover (Lid) by hand while cleaning to prevent accidental closing and injury.

Frequently Asked Questions

Question	Response
1. Can I cook frozen food on my George Foreman Grill?	It is preferable that food be defrosted before placing on the George Foreman Grill. Make sure that the Grill is preheated, see preheat instructions, before placing food on the grilling plate.
2. Can I cook kabobs on the George Foreman Grill?	Yes. In order to protect the non-stick surface use wooden skewers. We recommend that you soak the skewers first in water for about 20 minutes. This will keep the skewers from burning.
3. After cooking with garlic, how can I remove the smell of the garlic from the surface of my George Foreman Grill?	After cleaning your George Foreman Grill according to the "User Maintenance Instructions" make a paste of baking soda and water and spread on the surface of the Grill. Allow it to sit for a few minutes and then wipe away with a damp sponge or cloth.
4. How can I cook hot dogs on my George Foreman Grill?	Preheat your Grill for 5-minutes. Place the hot dogs lengthwise on the Grill. Close the Lid and cook for 2-1/2 minutes or until desired browning is achieved.
5. Can hash browns be prepared on my George Foreman Grill?	Yes, self-browning hash browns can be prepared by preheating the Grill for 5 minutes. Add hash browns onto the Grill surface, close the Lid, and cook for approximately half the time stated on the package for oven preparation.
6. Any other cooking suggestions?	Fresh peppers can be grilled for 2-3 minutes for skinning purposes. Grilled cheese sandwiches can also be cooked on your George Foreman Grill.

LIMITED ONE-YEAR WARRANTY

Warranty Coverage: This product is warranted to be free from defects in materials or workmanship for a period of one (1) year from the original purchase date. This product warranty is extended only to the original consumer purchaser of the product and is not transferable. For a period of one (1) year from the date of original purchase of the product, our Repair Center will, at its option, either (1) repair the product or (2) replace the product with a reconditioned comparable model. These remedies are the purchaser's exclusive remedies under this warranty.

Warranty Service: To obtain warranty service, you must call our warranty service number at 1-800-233-9054 for return instructions on how to deliver the product, in either the original packaging or packaging affording an equal degree of protection to the Repair Center specified below. You must enclose a copy of your sales receipt or other proof of purchase to demonstrate eligibility for warranty coverage.

To return the appliance, ship to:

ATTN: Repair Center
708 South Missouri Street
Macon, MO 63552 USA

To contact us, please write to, call, or email:

Consumer Relations Department
PO Box 7366
Columbia MO 65205-7366 USA
1-800-233-9054
E-mail: consumer_relations@toastmaster.com

What Is Not Covered: This warranty does not cover damage resulting from misuse, accident, commercial use, improper service or any other damage caused by anything other than defects in material or workmanship during ordinary consumer use. This warranty is invalid if the serial number has been altered or removed from the product. This warranty is valid only in the United States and Canada.

LIMITATION ON DAMAGES: THERE SHALL BE NO LIABILITY FOR ANY INCIDENTAL OR CONSEQUENTIAL DAMAGES FOR BREACH OF ANY EXPRESS OR IMPLIED WARRANTY OR CONDITION ON THIS PRODUCT.

DURATION OF IMPLIED WARRANTIES: EXCEPT TO THE EXTENT PROHIBITED BY APPLICABLE LAW, ALL IMPLIED WARRANTIES AND CONDITIONS, INCLUDING, WITHOUT LIMITATION, IMPLIED WARRANTIES AND CONDITIONS OF MERCHANTABILITY AND FITNESS FOR A PARTICULAR PURPOSE OR USE ON THIS PRODUCT ARE LIMITED IN DURATION TO THE DURATION OF THIS WARRANTY.

Some jurisdictions do not allow the exclusion or limitation of incidental or consequential damages, or allow limitations on how long an implied warranty lasts, so the above limitations or exclusions may not apply to you. This warranty gives you specific legal rights and you may have other rights under the laws of your jurisdiction.

For more information on our products, visit our website:
www.maxim-toastmaster.com.